

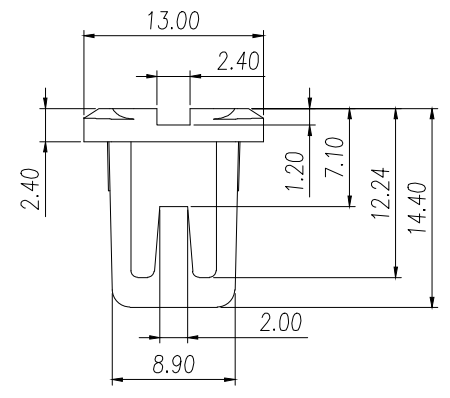

REVISION RECORD			
REV.	CONTENT	MOD.	DATE
△	初版发行		

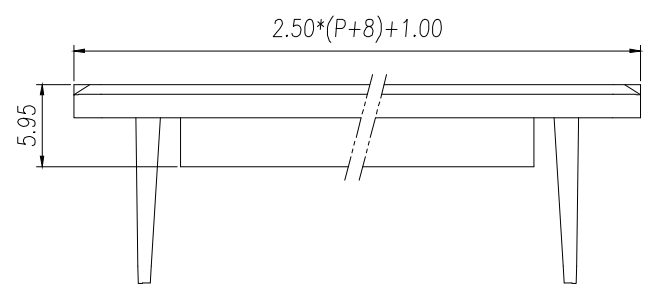
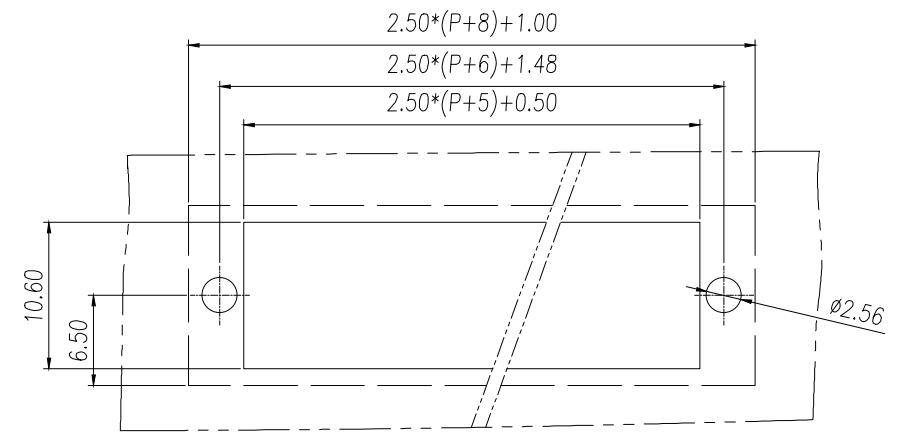
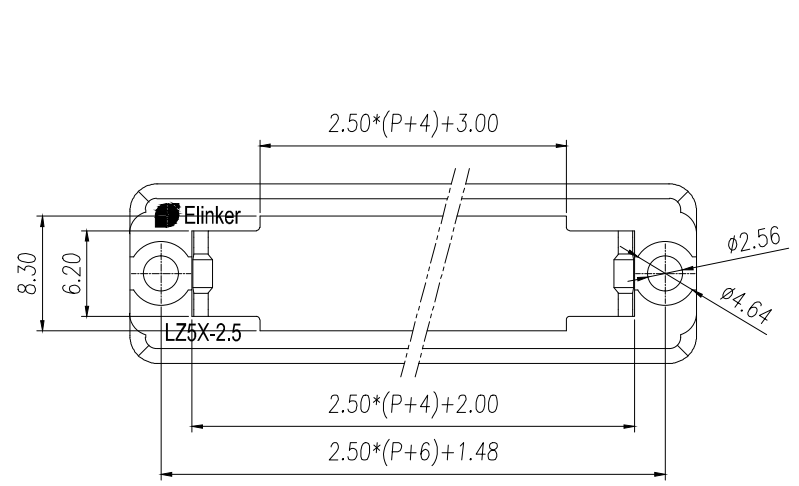

技术要求:

1. 避免色差、明显变形和缩水现象
2. 最大毛边为0.05mm

	pitch dimension			Nominal dimension					—
	over 0 to 6	over 6 to 10	over 10 to 24	over 0 to 30	over 30 to 60	over 60 to 100	over 100 to 150		
variable range	0 to 6	6 to 10	10 to 24	0 to 30	30 to 60	60 to 100	100 to 150		□ ○
Tolerance	±0.1	±0.15	±0.25	±0.2	±0.3	±0.5	±0.7	±1.0	0.05/10

1.	LZ5X-2.5-主体	1187A0YXXAV	1	PC	
NO.	NAME OF PART	NO. OF PART	Q'TY	MATERIAL	NOTES
DES.	WY	DATE 2022/07/18	UNITS	MM	THIRD ANGLE PROJECTION
CHK.		DATE	SIZE	A4	1 of 1
APP.		DATE	SCALE	1:1	REV: V0
 上海联捷电气有限公司 Shanghai Elinker Electric CO.,LTD				TITLE	LZ5X-2.5-XXP-1Y-00A LZ5X-2.5-主体