

REVISION		RECORD	
REV.	CONTENT	MOD.	DATE
△	初版发行		

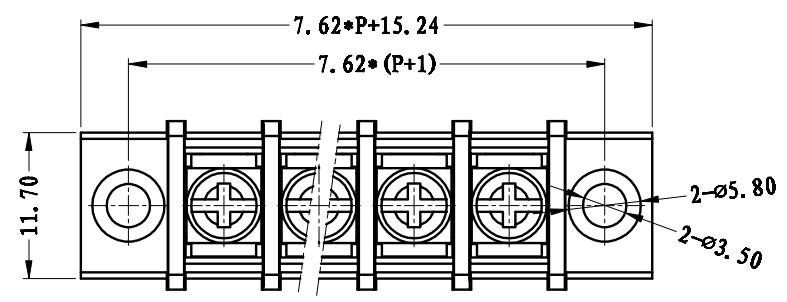

NOTES:
 Pitch : 7.62mm
 Rated Voltage : 300V
 Rated Current : 15 A
 Withstand Voltage :
 AC2500V for 1 minute
 Insulation Resistance :
 5MΩ / DC500V
 Using Temperature Range :
 -40℃ ~ +130℃
 Wire range : 22~14 AWG
 Screw Torque Value : 0.5Nm

技术要求:
 间距: 7.62mm
 额定电压: 300V
 额定电流: 15A
 耐电压值: AC2500V/min
 绝缘阻抗: 5MΩ/DC500V
 使用条件: -40℃~+130℃
 适用线规: 22~14 AWG
 螺丝扭矩: 0.5Nm

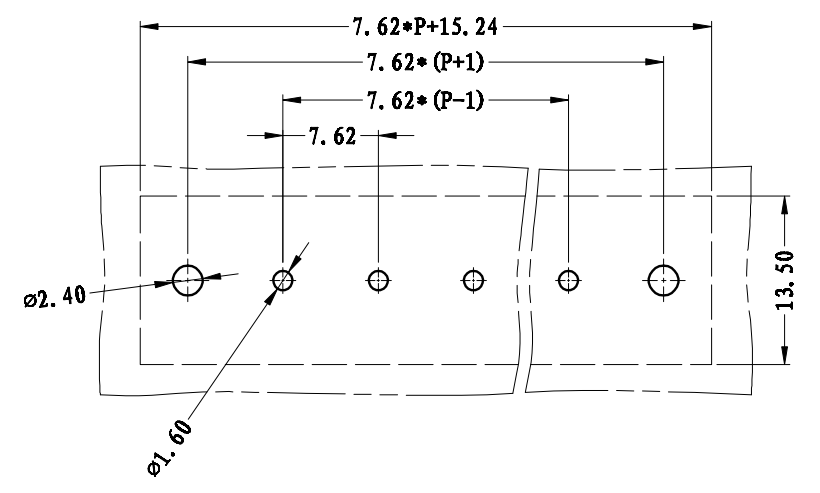
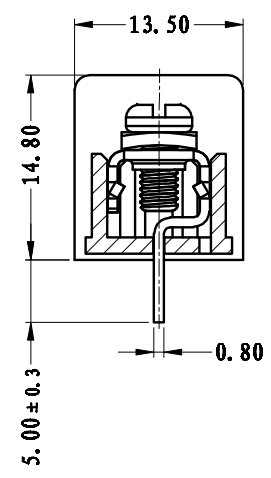
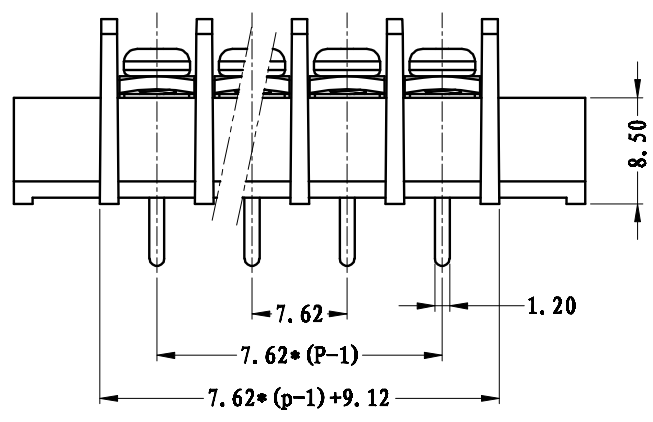

	pitch dimension			Nominal dimension					— /
	over	over	over	over	over	over	over	over	
variable range	0	6	10	0	30	60	100	150	□
	to	to	to	to	to	to	to		○
	6	10	24	30	60	100	150		
Tolerance	±0.1	±0.15	±0.25	±0.2	±0.3	±0.5	±0.7	±1.0	0.05/10

3	M3*6-6*6	SQFFA306023V	P	碳钢	三价铬钝化彩锌
2	LW1C-7.62-焊片	5010B0001AV	P	黄铜	镀镍锡
1	LW1M-7.62-主体	5010M07XXAV	1	PBT	
NO.	NAME OF PART	NO. OF PART	QTY	MATERIAL	NOTES
DES.	ARKINE	DATE	11-05-10	UNITS	MM
CHK.		DATE		SIZE	A4
APP.		DATE		SCALE	1: 1
				DWG NO.	SP-2-5010005
				REV:	VO
上海联捷电气有限公司 Shanghai Hlinker Electric C.O., LTD				TITLE	LW1MC-7.62-XP-1Y-00A
					LW1MC-7.62-成品