

REVISION		RECORD	
REV.	CONTENT	MOD.	DATE
①	初版发行		

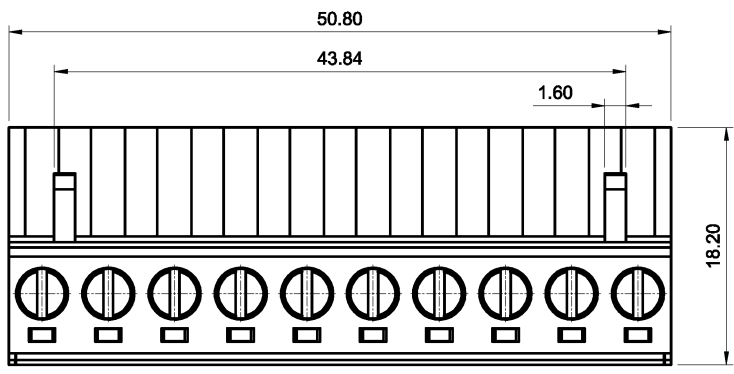
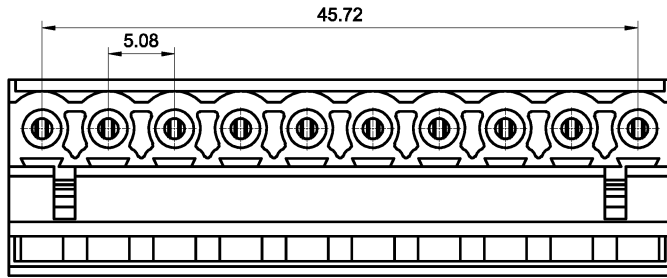

NOTES:

1. Voltage Rating: 300V, Current Rating: 15A
2. PITCH: 5.08mm
3. Insulation Withstands Voltage: AC2500V/min
4. Insulation Resistance: 500MΩ or more at DC500V
5. Using Temperature Range: -40° C - +105° C
6. Suitable Electric Wire: 28-12AWG
7. Screw Torque Value: 0.5 N.m

技术要求:

1. 额定电压: 300V, 额定电流: 15A
2. 间距: 5.08mm
3. 耐电压值: AC 2500V/min
4. 绝缘阻抗500兆欧
5. 使用条件: -40° - +105°
6. 适用线规: 28-12AWG
7. 螺丝扭矩:

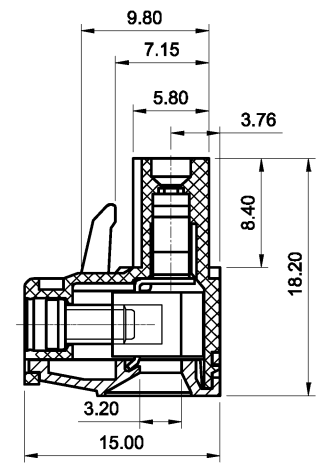

	pitch dimension			Nominal dimension					— /
	over 0	over 6	over 10	over 0	over 30	over 60	over 100	over 150	
variable range	to 6	to 10	to 24	to 30	to 60	to 100	to 150		□ ○
Tolerance	±0.1	±0.15	±0.25	±0.2	±0.3	±0.5	±0.7	±1.0	0.05/10

5.	LC1-5.08-夹子	1001B0001AV	10	磷青铜	镀镍		
4.	LC1-5.08-铜方块	F1A0BLC5083V	10	黄铜	镀镍		
3.	LC1-5.08-螺丝	SPOYA305302V	10	碳钢	三价铬钝化彩锌		
2.	LC1-5.08-盖子	1001C4010AV	1	PA66-V0	绿色		
1.	LC1-5.08-主体	1001A4010AV	1	PA66-V0	绿色		
NO.	NAME OF PART	NO. OF PART	Q'TY	MATERIAL	NOTES		
DES.	WL	DATE	18-05-08	UNITS	MM	THIRD ANGLE PROJECTION	SHEET
CHK.		DATE		SIZE	A4	①	1 of 1
APP.		DATE		SCALE	1:1	DWG NO. SP-1-10010A01	REV: V0
上海联捷电气有限公司 Shanghai Hlinker Electric C.O., LTD				TITLE		LC1-5.08-10P-140-00A	
						LC1-5.08-成品	